



charcoal: KD-AD-CG



black: KD-AD-BL



cloud: KD-AD-CW



leaf: KD-AD-LG



apple red: KD-AD-AR



driftwood: KD-AD-DW



navy blue: KD-AD-NB



sunset: KD-AD-OR



sky: KD-AD-SB

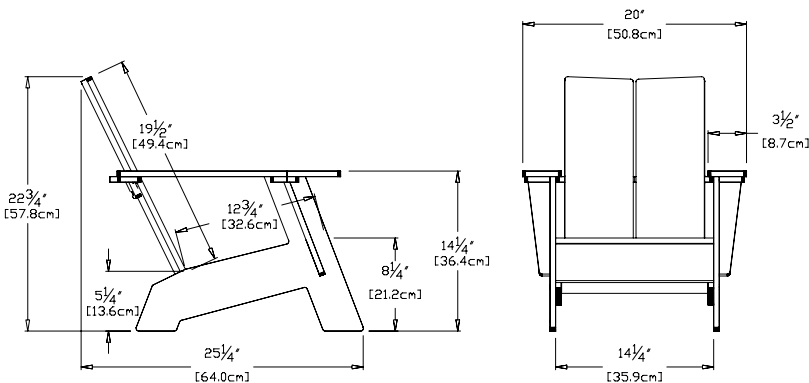

collection: kids
material: 100% recycled HDPE
dimensions: width: 20" (50.8cm)
 depth: 25.25" (64.0cm)
 height: 22.75" (57.8cm)
weight: 16 lbs (7.3kg)



128
reclaimed
milk jugs

shipping dimensions: 22" x 18" x 6"
shipping weight: 19 lbs (8.6kg)



flat pack shipped
some assembly required

