



SHARE YOUR LOLL



5 YR WARRANTY
 Loll Designs strives to build long-term relationships based on confidence and trust with our customers. We sit beside, on top, and beneath the quality of our fine furniture and will make things right if you are not completely satisfied with your purchase. Loll Designs hereby guarantees that the piece will be of good quality and workmanship, free from faults and defects. Loll warrants that all components will not fail, under normal use, for five years from the year mark on the piece or the date of purchase. *For commercial orders the warranty is three years.

PRODUCT CARE
 Your new Loll furniture is a no maintenance product. You'll never need to paint or stain it and it can be left outside all year regardless of the season. It will not rot, even if left standing in water. Nonetheless, we're pretty sure your Loll furniture will get a lot of use and will at some point need cleaning. We recommend a garden hose and incorporating a soft bristle brush. Adding a tablespoon or two of your favorite eco-friendly soap to the wash will get everything squeaky clean. Mineral deposits left over from hard water can be removed with a solution of vinegar and water. Loll offers a cleaning kit that has everything you need for great results. Also see our cleaning video at lollidesigns.com/videos.

Loll Designs inspires people to appreciate the outdoors.

ASSEMBLY INSTRUCTIONS & PRODUCT INFO:
 LOLLVAGGER BENCH



BLOCK & BOLT INSTALLATION

Insert bolts through countersunk hole side of blocks as shown below.

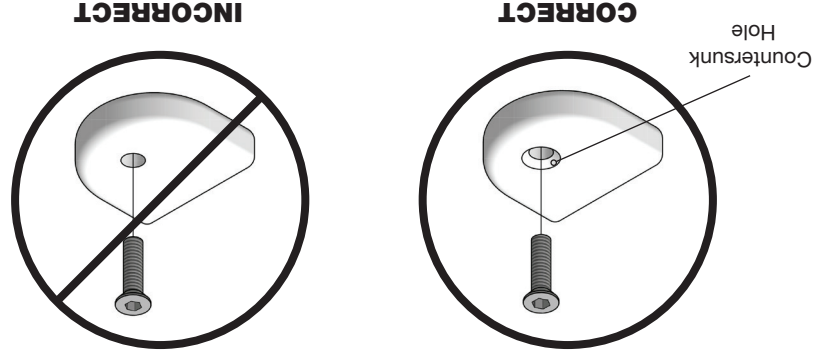

LOLL TOOL
 Locate the box marked "Tool Included" before beginning assembly.

**** Please Recycle the BOX and paper packaging. The green plastic stretch wrap we use is compostable.**

To avoid damaging furniture perform the assembly of your Loll furniture on a clean soft surface like a blanket, carpet, or the flattened cardboard box the furniture was shipped in. Components should not be unnecessarily forced together! If it seems parts aren't fitting together you likely have something wrong and you should reread the instructions to ensure you are aligning the proper components. If your piece of furniture requires "Blocks" for assembly one side may have protective film on it. This surface is hidden after assembly so the film can remain on the block or it can be removed. Use a Cordless Screw Gun if you have one and know how to use it. Set the clutch setting at medium torque. We do not recommend using an electric drill with a cord and without a clutch to install bolts in inserts as you can easily overtighten and damage the product. All bolts come standard with a thread coating to reduce bolts loosening after assembly while still allowing removal and reuse of the bolt. Start all bolts by hand, with the Allen Key, or the Loll Tool and tighten firmly until parts are drawn tight together and you can't muscle the bolt any tighter; it's virtually impossible to over tighten by hand. Watch the assembly videos at www.lollidesigns.com/videos for even more information and visual aids. If you have more questions please contact your Loll Sales Associate or Customer Service for support at 877.740.3387. **A Pro Tool Kit!** can also be purchased from Loll for multi piece assembly jobs.

Scan for assembly tips and videos



ASSEMBLY TIPS

Please read before beginning assembly!
 Sometimes accidents occur. Please inspect your Loll furniture when you receive it to make sure that it has not been damaged during shipping. If damage has occurred please take digital pictures of the damaged furniture and the box it was shipped in, and email them to sales@lollidesigns.com or call Customer Service using our toll free number: 877.740.3387, ext. 1. The damage will be assessed and you will be contacted with a solution to the problem. It may be helpful to save all of your packaging material in case a return is necessary.

INCLUDED PARTS

	COUNT		COUNT		COUNT
BENCH SLATS	4	RIGHT & LEFT RAILS	2	SIDE	2
LEFT & RIGHT LEG	4	LEFT & RIGHT L BLOCK	4	SQUARE BLOCK	14
				7/8" BOLTS (ORANGE)	30

ASSEMBLY INSTRUCTIONS

* It is very important that you finger tighten all bolts into inserts to ensure that you do not cross-thread bolts and inserts before tightening. It will also be easier if you wait to tighten bolts until you have all bolts installed and the piece completely assembled. This will allow for more movement of individual pieces and help in aligning holes with inserts. Use the Allen Tool provided to finish tighten bolt until snug.

1 ATTACH RAILS & BENCH SLATS

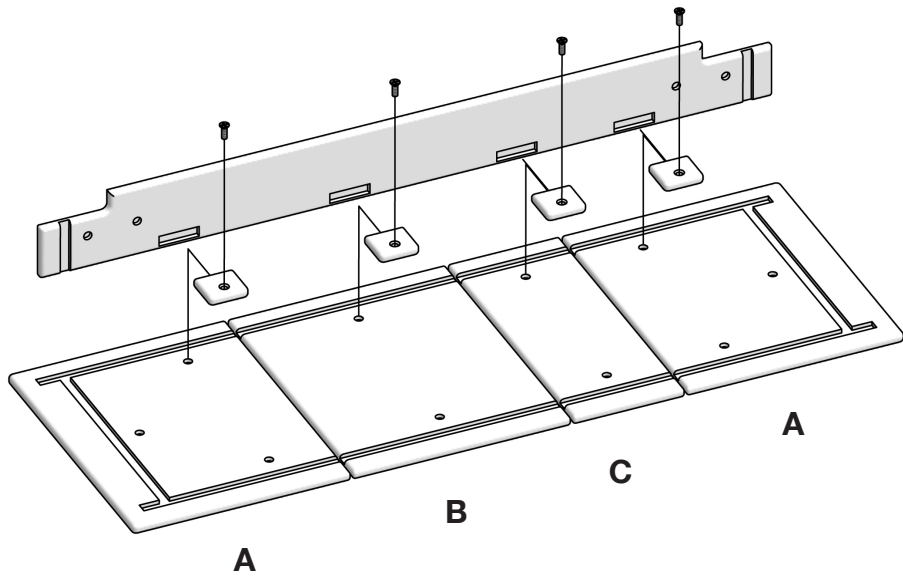

*Please read **Assembly Tips** before beginning assembly. Lay Bench Slats upside down on a clean flat surface arranged in the order shown above. Fit long edge of the Rail with cut outs in Bench Slats. Place Square Blocks (recessed hole side out) in to the Rail cut outs. Insert bolts through the blocks into the Bench Slats threaded holes and tighten. Repeat for opposite Rail.

2 ATTACH SIDES

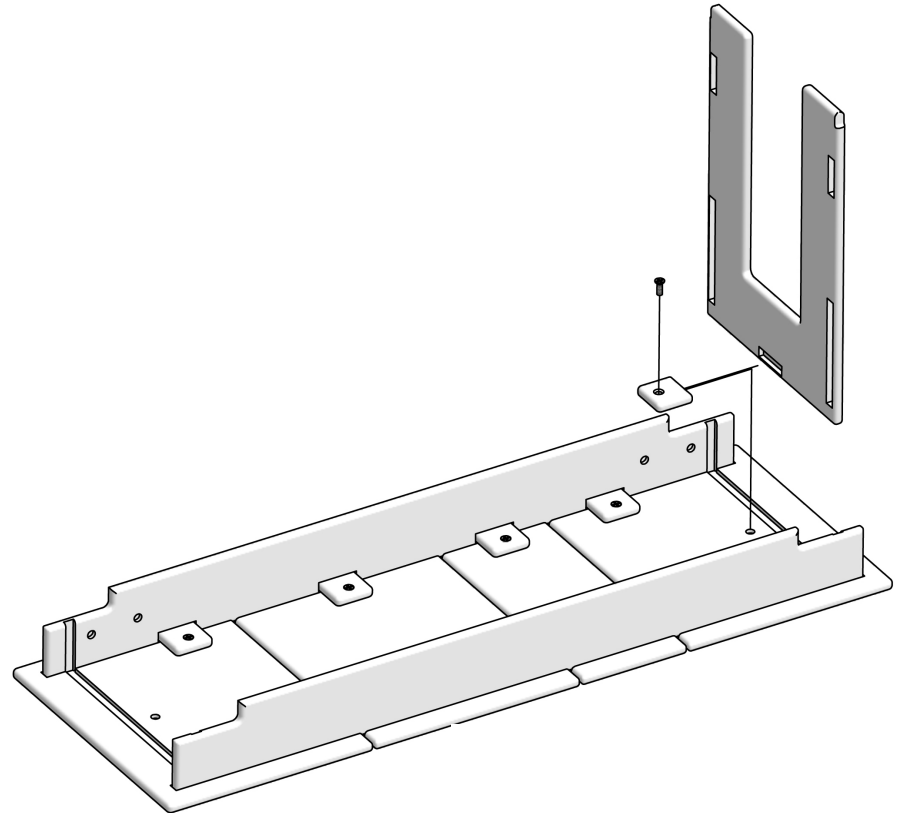
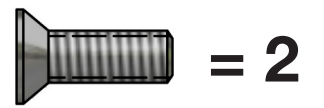

Fit Side in Rail cutouts and slide into the Bench Slate A cut out. Attach using square block and bolt. Repeat for opposite Side.

3 ATTACH LEGS

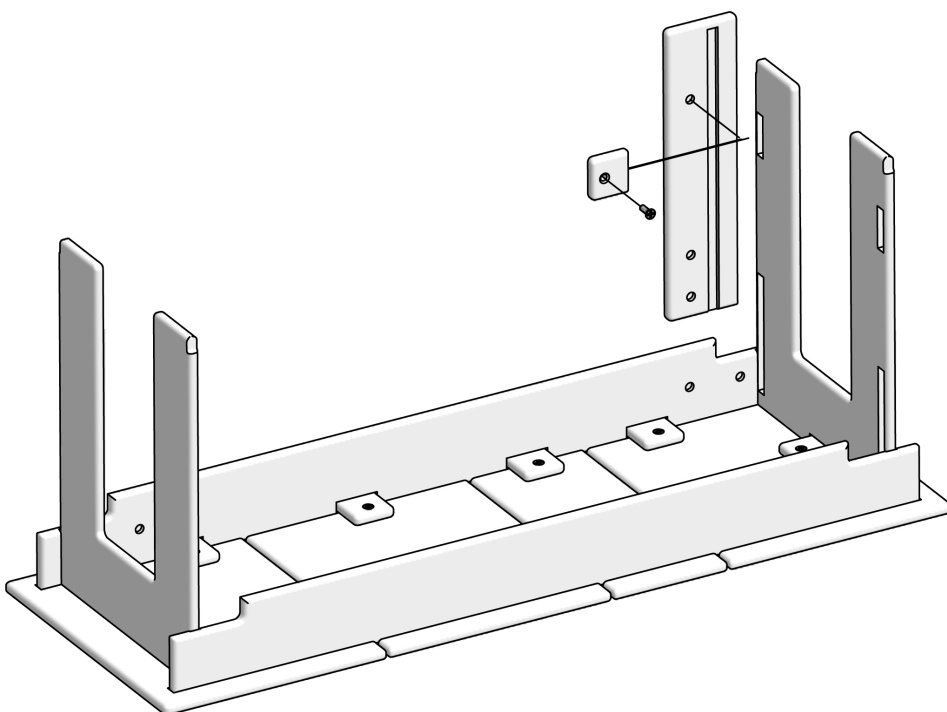

Fit cut out of the Leg with the edge of the Side. Place Square Block into cut out of the Side. Insert a bolt through the block into the Leg's threaded holes and tighten.

4 ATTACH L BLOCKS

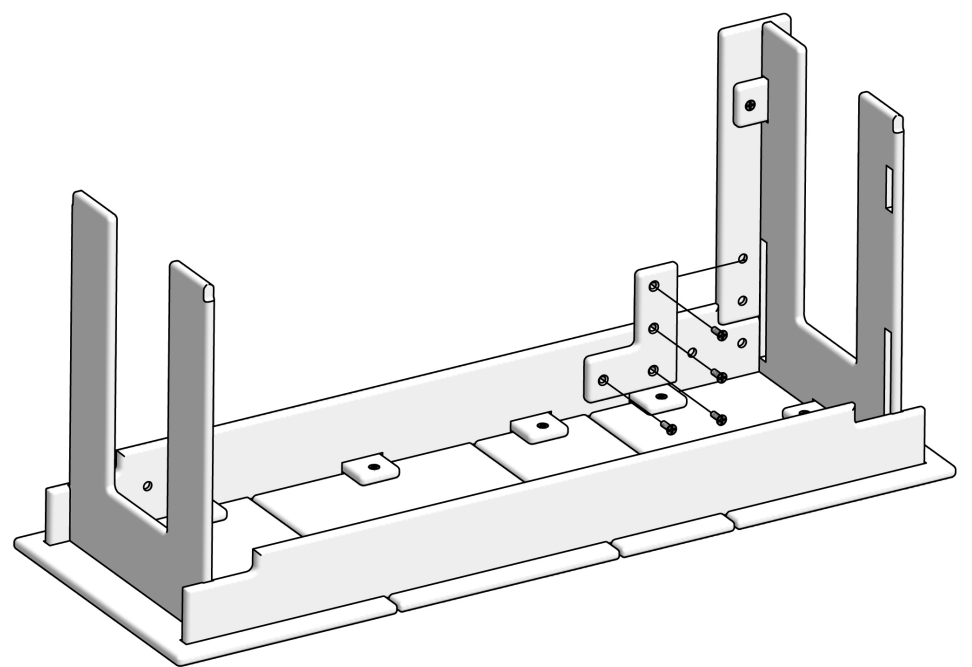
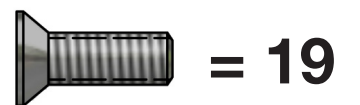

Fit L Block long edge (recessed holes side out) into long cut out of same size of the Side. Align L Block holes with Leg and Rail threaded holes, and attach with bolts.

Repeat Step 3 & 4 for remaining legs.

Complete assembly by securely tightening all bolts using provided wrench.